



## Type SBSB Load Cell



### Features 主要特点

- Single ended shear beam load cell
- Stainless steel construction
- Hermetically sealed
- High accuracy
- High stability
- Anti-explosion (option) 
- Easy to install
- Suitable for floor scales, blending & mixing systems, belt scales and batching Systems, etc.
- 悬臂梁式
- 优质不锈钢材质
- 全密封焊接
- 高精度
- 高稳定性
- 防爆(可选) 
- 安装简便、快速
- 适用于平台秤、搅拌站、皮带秤和配料秤等

### Schematic 接线方式

- |         |          |      |      |
|---------|----------|------|------|
| Red :   | + input  | 红色 : | + 激励 |
| Black : | - input  | 黑色 : | - 激励 |
| Green : | + output | 绿色 : | + 信号 |
| White : | - output | 白色 : | - 信号 |

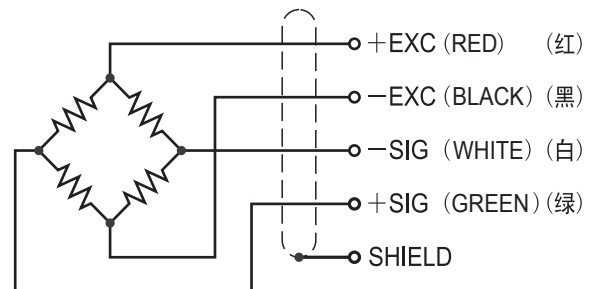

### Capacities 量程

250lb, 250kg, 500kg, 1000kg, 1500kg, 2000kg,  
2500kg, 5000kg

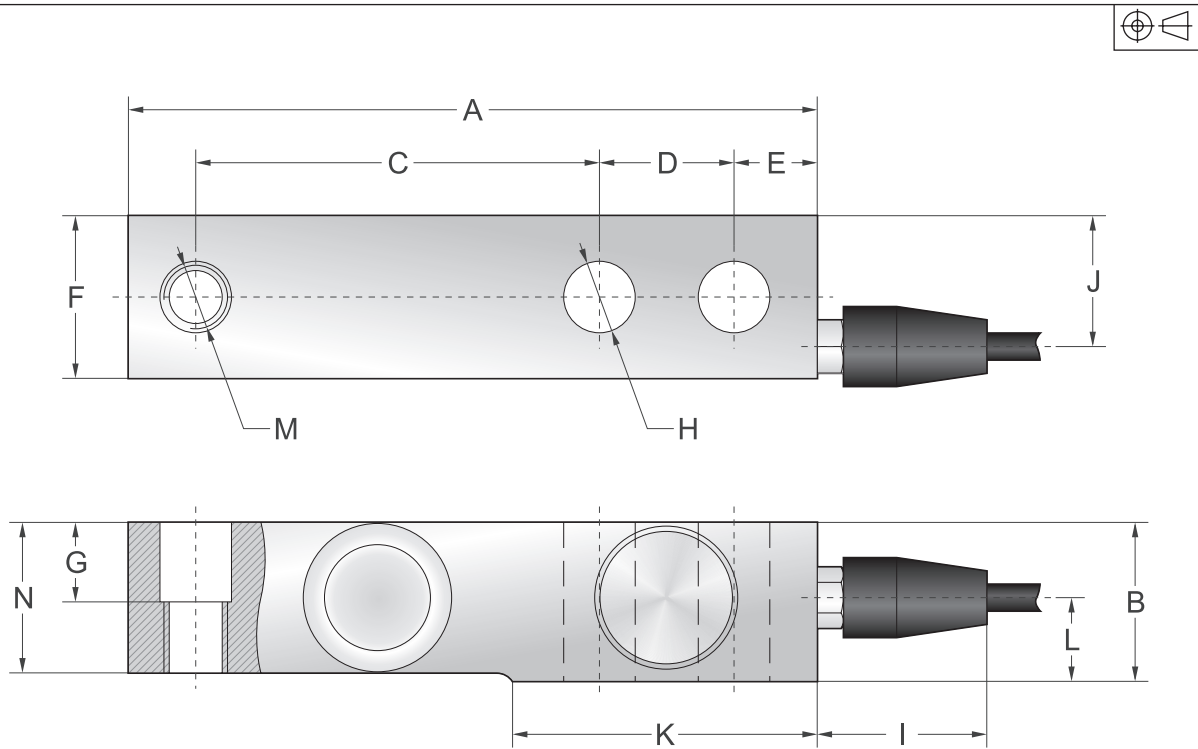
**Dimensions** 尺寸

Capacity/量程		A	B	C	D	E	F	G	H	I	J	K	L	M	N
250lb	mm	130	30	76.2	25.4	15.7	30.7	15	3×Ø13.5	32	24.7	57.5	15.8	1/2"-20 UNF	28.4
250kg ~ 2.5ts	mm	130	30	76.2	25.4	15.7	30.7	15	3×Ø13.5	32	24.7	57.5	15.8	M12×1.75	28.4
2.5t ~ 7.5ts	mm	171.5	36.5	95.3	38.1	19.1	36.5	17.5	3×Ø19.8	32	30.7	76.2	19.5	M18×1.5	34

**Specification** 技术参数

Rated Output	额定输出	2.0mV/V ±0.1% / 3.0mV/V ±0.1%
Zero Balance	零点平衡	±1% of rated output
Creep after 30 minutes	蠕变	±0.03% of rated output
Nonlinearity	非线性	±0.03% of rated output
Hysteresis	滞后	±0.03% of rated output
Repeatability	重复性	±0.03% of rated output
Temp. effect on output	灵敏度温漂	≤0.002% of applied output/°C
Temp. effect on zero	零点温漂	≤0.002% of rated output/°C
Safe Temp. Range	可用温度范围	-10°C to + 70°C
Temp. Compensated	温度补偿范围	-10°C to + 40°C
Safe Overload	安全载荷	150%
Input Impedance	输入阻抗	387 ohm ± 20 ohm
Output Impedance	输出阻抗	350 ohm ± 5 ohm
Insulation Resistance	绝缘阻抗	≥5000 M ohm (50V DC)
Rated Excitation	推荐激励电压	10V DC/AC
Maximum Excitation	最大激励电压	15V DC/AC
Cable Length	导线长度	6m
Cable Color Code	导线颜色	Red(+ E) Black(- E) Green(+ S) White(- S)