



TRANSCCELL TECHNOLOGY, INC.

TI-1680

DIGITAL WEIGHT INDICATOR

Setup / Operation Manual



Revision 1.4
June 6, 2016

975 Deerfield Parkway Buffalo Grove, IL 60089
Tel (847) 419-9180 Fax (847) 419-1515
<http://www.transcell.com>

TABLE OF CONTENTS

	<u>Page</u>
1. INTRODUCTION	- 1 -
2. INSTALLATION	- 1 -
2.1 Preparation.....	- 1 -
2.2 Making Wire Connections	- 2 -
2.3 Load Cell Connections	- 2 -
2.4 COM1 RS-232 Connections.....	- 3 -
2.5 Control I/O Connections.....	- 3 -
2.6 COM2 RS-232 Connections.....	- 3 -
2.7 Power Connections	- 3 -
3. CONFIGURATION.....	- 4 -
3.1 Overview	- 4 -
3.2 Accessing the Menus	- 4 -
3.3 Menu Structure.....	- 5 -
3.4 Setup Menu Descriptions	- 6 -
3.5 Setup Menu Procedures	- 9 -
3.6 User Menu Descriptions.....	- 10 -
3.7 User Menu Procedures	- 12 -
3.8 Batch Menu Descriptions	- 14 -
3.9 Batch Menu Procedures.....	- 14 -
3.10 Exiting the Menus.....	- 15 -
4. CALIBRATION	- 16 -
4.1 Calibration Overview	- 16 -
4.2 Zero Calibration (F16).....	- 16 -
4.3 Span Calibration (F17).....	- 16 -
4.4 View Calibration Values (F18).....	- 17 -
4.5 Key-in Zero Calibration Value (F19)	- 18 -
4.6 Key-in Span Calibration Value (F20)	- 18 -
5. OPERATION.....	- 19 -
5.1 Display.....	- 19 -
5.2 KEYBOARD	- 20 -
5.3 GENERAL SCALE OPERATION.....	- 21 -
WEIGHING AN ITEM.....	- 21 -
ENTERING A KNOWN TARE WEIGHT	- 22 -
CLEARING A TARE WEIGHT	- 22 -
ENTERING AN ID NUMBER	- 22 -
PROGRAMMING SET POINTS	- 22 -

PROGRAMMING OVER/UNDER VALUES.....	- 23 -
6. ADVANCED SCALE OPERATION	- 24 -
6.1 APPLICATION (F30) SUMMARY	- 24 -
6.2 STANDARD OUTPUTS	- 25 -
6.3 ACCUMULATION APPLICATION (F30 = 1).....	- 25 -
6.4 REMOTE DISPLAY APPLICATION (F30 = 2).....	- 25 -
6.5 PIECE COUNT APPLICATION (F30 = 3).....	- 25 -
6.6 HOLD APPLICATION (F30 = 5).....	- 26 -
6.7 CHECKWEIGHER APPLICATION (F30 = 6).....	- 27 -
6.8 BATCHING APPLICATION (F30 = 7).....	- 27 -
6.9 TRUCK WEIGH IN/WEIGH OUT APPLICATION (F30 = 8)	- 28 -
7. LEGAL FOR TRADE SEALING.....	- 30 -
APPENDIX A: SPECIFICATIONS	- 31 -
APPENDIX B: SERIAL PORT INFORMATION	- 32 -
SERIAL PORT MODES.....	- 32 -
DEMAND DUPLEX MODE	- 32 -
CONTINUOUS DUPLEX MODE	- 32 -
AUTO PRINT MODE	- 32 -
OUTPUT STRING	- 33 -
TEXT PRINT TICKET	- 34 -
STRING FORMAT 1 (Condec Demand String)	- 35 -
STRING FORMAT 2 (Condec Continuous String)	- 36 -
APPENDIX C: DISPLAYED ERROR CODES	- 38 -
APPENDIX D: WIRING EXTERNAL OUTPUT RELAYS.....	- 39 -
OUTPUTS.....	- 39 -
INPUTS.....	- 40 -

©Transcell Technology, Inc. 2010-2016. All rights reserved.

The information contained herein is the property of Transcell Technology and is supplied without liability for errors or omissions. No part may be reproduced or used except as authorized by contract or other written permission. The copyright and the foregoing restriction on reproduction and use extend to all media in which the information may be embodied.

Contents subject to change without notice.

1. INTRODUCTION

The TI-1680 Digital Indicator is a multi-purpose, industrial grade weight indicator. The Table below summarizes the main physical parameters.

MODEL	DISPLAY TYPE	ENCLOSURE TYPE	POWER SOURCE
TI-1680	LED	Stainless Steel	100-240 VAC, 50/60 Hz 30W

The unit can readout up to 50,000 display divisions and can supply enough current for up to 8-350 Ω load cells. All setup parameters may be entered via the front panel keys, including calibration.

If your Model TI-1680 Series Digital Indicator is part of a complete scale or has already been installed for you, then you may skip to the operating instructions. Prior to using the indicator, please read this manual carefully and completely. Store the manual in a safe and convenient place so it will be available if you have questions concerning the operation of the scale.

FCC NOTE

This equipment has been tested and found to comply with the limits for a Class A digital device, pursuant to Subpart J of Part 15 of the FCC Rules. These limits are designed to provide reasonable protection against harmful interference when the equipment is operated in a commercial environment. This equipment generates, uses and can radiate radio frequency energy and, if not installed and used in accordance with the instructions manual, may cause harmful interference to radio communications. Operation of this equipment in a residential area is likely to cause harmful interference in which case the user will be required to correct the interference at his/her own expense.

2. INSTALLATION

2.1 Preparation

Any precision instrument requires a suitable environment in which to operate as intended. Please review each of the following prior to installation:

Electrical Power

The TI-1680 indicator has been designed to operate from 100 to 240 VAC at 50/60 Hz. All units ship with the appropriate power plug for its area of intended use.

To avoid electrical noise interference and/or stray AC electrical transients, try to operate the indicator from a circuit separate from any equipment containing inductive devices such as a contactor coil, solenoid, relay coil, or motor. Be sure to use shielded cables for the load cell connections (ground shield wire at indicator) and run these cables away from your AC/DC power cables if possible.

In extreme cases, it may be necessary to install surge suppressors, line conditioners or even UPS (Uninterruptible Power Supplies) systems (not included).

Environment

- Avoid installing the indicator in areas of direct sunlight or high humidity
- Avoid sudden temperature change – if this is unavoidable allow equipment to ‘soak’ at a constant temperature for at least three hours before use
- Ensure that steady, clean AC power is available to the unit

Remember that the installer is ultimately responsible to assure that a particular installation will be and remain safe and operable under the specific conditions encountered.

2.2 Making Wire Connections

Remove the rear cover by removing the six acorn nuts that secure it to the main enclosure and set aside. Route all cables thru the cord grips (also called cable glands). All terminals are located on the main circuit and are spring loaded.

At each terminal, first strip some insulation away, push down on the red release tab with a small screwdriver, insert the wire into the terminal and then allow the red release tab to spring back into its original position. For stranded wires, you may find that crimping on a ferrule or tinning with solder will improve the integrity of this connection.

Caution! Disconnect power source from indicator prior to removing rear cover.

When all connections have been completed tighten the cord grips, re-install the rear cover and tighten the nuts.

NOTE: all cables entering the TI-1680 should be grounded to the metal enclosure.

2.3 Load Cell Connections

Connect your shielded load cell cable to terminal block J1 using the table below. Pin 1 is on the right.

TIP: You should have the color codes handy for your load cell / junction box / weighing platform before doing so.

Load Cell Terminal Block J1

Pin No.	Marking	Function
1	E+	+ Excitation
2	SEN+	+ Sense
3	E-	- Excitation
4	SEN-	- Sense
5	S+	+ Signal
6	S-	- Signal
7	SH	Shield

NOTE: If not utilizing Sense wires, be sure to jumper (shunt) R47 and R48 which are located adjacent to Terminal Block J1.

2.4 COM1 RS-232 Connections

Connect your COM1 RS-232 serial communications cable to terminal block J10 using the table below. Pin 1 is on the right.

COM1 RS-232 Terminal Block J10

Pin No.	Markings	Function
1	RxD1	Receive Data
2	TxD1	Transmit Data
3	CTS	Clear to Send
4	RTS	Request to Send
5	GND	Signal Ground

2.5 Control I/O Connections

Connect your control I/O cables to terminal block J4 using the table below. Pin 1 is on the right.

A +5VDC terminal is also included for connection to the outputs if an external supply is not available. This terminal can safely supply up to 500 mA of current.

The outputs are labeled OUT1-OUT4. The single remote input is triggered by simple contact closure. **For more information, including wiring diagrams, please see Appendix D.**

Control I/O Terminal Block J4

Pin No.	Markings		Pin No.	Markings
1	+5V		6	OUTPUT1
2	GND		7	OUTPUT2
3	INPUT		8	OUTPUT3
4	GND		9	OUTPUT4
5	CATCHDIODE			

2.6 COM2 RS-232 Connections

Connect your COM2 RS-232 serial communications cable to terminal block J9 using the table below. Pin 1 is on the right.

COM2 RS-232 Terminal Block J9

Pin No.	Markings	Function
1	RxD2	Receive Data
2	TxD2	Transmit Data
3	CTS	Clear to Send
4	RTS	Request to Send
5	GND	Signal Ground

2.7 Power Connections

The TI-1680 indicator ships with an AC line cord pre-installed to the indicator. It has been pre-wired to Terminal Block J7 at the factory. Simply plug the unit into a standard wall outlet.

3. CONFIGURATION

3.1 Overview

The indicator contains two main configuration menus:

- The Setup (“F”) menu, which configures and calibrates the indicator to your weigh platform
- The User (“A”) menu, which configures the serial communication ports and enables some user options
- The Batching (“B”) menu, which configures the I/O for process control and checkweigher functions

All menus consist of several menu selections, each with their own sub-menu of selections or programming procedures. To configure the indicator, you must first enter the appropriate menu mode. Once there, four of the front panel keys become directional navigators to move around in the menus, and one key is used to save or SET the selections.

3.2 Accessing the Menus

To access the Setup (“F”) menu:

1. Power off the indicator.
2. Locate the slide switch on the rear cover and move it to the opposite position.
NOTE: A metal plate conceals the slide switch; remove the two drilled-head screws and cover plate to access the slide switch.
3. Power on the indicator.
The display shows “ PASS_ ” to indicate that you need to enter a password to access Setup Menu mode.
4. Key-in the password (1397) and then press Enter key
The display shows ”F 1” to indicate that you are in Setup Menu mode.

To access the User (“A”) menu:

1. Power off the indicator.
2. Locate the slide switch on the rear cover and move it to the opposite position.
NOTE: A metal plate conceals the slide switch; remove the two drilled-head screws and cover plate to access the slide switch.
5. Power on the indicator.
The display shows “ PASS_ ” to indicate that you need to enter a password to access User Menu mode.
3. Key-in the password (1793) and then press SET (MODE) key
The display shows ”A 1” to indicate that you are in User Menu mode.

To access the Batch (“B”) menu:

1. Power off the indicator.
2. Locate the slide switch on the rear cover and move it to the opposite position.
NOTE: A metal plate conceals the slide switch; remove the two drilled-head screws and cover plate to access the slide switch.
6. Power on the indicator.
The display shows “ PASS_ ” to indicate that you need to enter a password to access User Menu mode.
3. Key-in the password (1234) and then press SET (MODE) key
The display shows ”B 1” to indicate that you are in Batch Menu mode.

3.3 Menu Structure

All menus consist of a top level (heading) and a secondary level. The top level contains the code (e.g. F1) for the parameter to be configured. The secondary level contains the selection list or allows access to a programming sequence.

Use the directional keys to move around in the Menu Structure shown below.

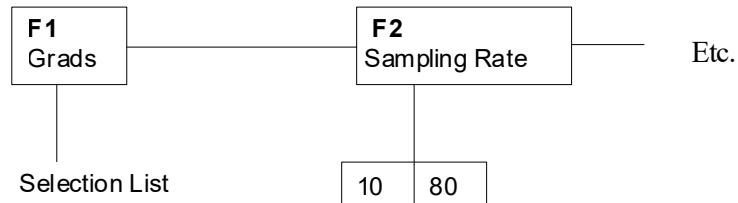

1. To move to a new heading, use the TARE (left) or PRINT (right) key to move right or left in the Menu.
2. To move to the selection or programming level, press the ZERO (down) key once. The currently saved selection is shown.
3. To view the available selections for the current heading, use the TARE (left) or PRINT (right) key to move through the selection field.
4. To save a new selection, press the MODE (Set) key. To exit without saving, press the UNITS (up) key to return to the current heading. **NOTE:** Some menus require that you press the MODE (Set) key to return to the current heading, e.g. F1.
5. Repeat Steps 2 through 5 until the Menu is programmed.



To exit any setup Menu, press the C/CE key. To exit all the way out return the slide switch to its original position.

3.4 Setup Menu Descriptions

This section provides more detailed descriptions of the selections found in the Setup Menu Chart. Factory-set defaults are shown in bold; **(NA)** for North America and **(E)** for Europe.

NOTE: Some selections are subject to local legal metrology regulations

CODE/NAME	DESCRIPTION	SELECTION LIST
F1 Graduations	Specifies number of full-scale graduations, i.e. capacity ÷ division. For example, if scale is to be 5000 lb x 1 lb, then F1 should be set to 5000 (5000 ÷ 1). Value should be consistent with legal regulations and environmental limits on the useful system resolution. Pressing the ZERO key to scroll down one level begins the sequence.	Key-in 100 - 50000 10000 (NA) 6000 (E)
F2 Sampling Rate	Sets the sampling rate in Hertz (measurements per second). Use 10 Hz for most applications or 80 Hz for extra fast response time	10√ (NA/E) 80
F3 Zero Track Band	Selects the range within which the scale will automatically zero. Note that the scale must be in standstill to automatically zero. Selections are in display divisions per second (d/s).	0d 0.5d √ (NA/E) 1d 3d 5d
F4 Zero Range	Selects the range (expressed as a percentage of full scale capacity) within which the scale may be zeroed. Note that the indicator must be in standstill to zero the scale.	100% (NA) 1.9% 2% (E) 20%
F5 Motion Band	Sets the level at which motion is detected. If motion is not detected, the scale can process a Print or Zero command. Maximum value varies depending on local regulations. Expressed as scale divisions per second (d/s). Pressing the ZERO key to scroll down one level begins the sequence.	Key-in 0.0d/s – 32.0d/s 1.0d/s (NA/E)
F6 Digital Filter	Averages weight readings to produce higher stability. Choose the speed that works best for your application. "FAST" = Fast "nnEd" = Medium "SLo" = Slow	FAST nnEd√ (NA/E) SLo
F7 Overload Limit	Selects the formula which determines the point at which the indicator shows overload. All selections are based on the primary unit selected in F8. "FS" = Full scale capacity.	FS FS + 2% (NA) FS + 5% FS + 1d FS + 9d (E)
F8 Calib. Unit	Selects the primary base unit to be used in the calibration process. Also the default unit for normal operation. "1" = primary unit is lb. "2" = primary unit is in kg.	1 (NA) 2 (E)
F9 Display Divisions	Determines the desired weight increments. Value should be consistent with legal requirements.	1 (NA) 2 5 (E)
F10 Decimal Pt.	Determines location of the decimal point.	0 (NA) 0.0 (E) 0.00 0.000 0.0000 00

CODE/NAME	DESCRIPTION	SELECTION LIST
F11 Custom Unit Multiplier	Actuates the function that allows you to enter a multiplier for the custom unit., i.e. the conversion factor that you would divide the calibration unit by in order to obtain the custom unit of weight. Pressing the ZERO key to scroll down one level begins the sequence.	Key-in 0.0001 - 1000 1.0 (NA/E)
F12 Power On Zero (IZSM)	Allows you to enable or disable power-on zero (IZSM). "0" = Disable IZSM "1" = Enable IZSM	0 (E) 1 (NA)
F14 Units Conversion	Allows the UNITS key to be disabled so that an operator cannot accidentally press the key and change the displayed units. "0" = Disable the Units key "1" = Enable the Units key	0 (E) 1 (NA)
F15 Third Unit Selection	Selects the third unit to appear after lb and kg when toggling the UNITS key. "0" = No Third Unit, "1" = Grams, " 2" = oz, "3" = custom unit	0√ (NA/E) 0-3
F16 Zero Calibration	Places indicator into the zero calibration routine. Scrolling down with the ZERO key one level begins the procedure.	Press ZERO key to begin sequence
F17 Span Calibration	Places indicator into the span calibration routine. Scrolling down with the ZERO key one level begins the procedure.	Press ZERO key to begin sequence
F18 View Calibration	Actuates the function that allows you to view both the zero and span calibration value. The values displayed in this function are valid only after Calibration (F16 & F17) has been successfully completed. Scrolling down with the ZERO key one level begins the procedure. Multi-point cal	Press ZERO key to begin sequence
F19 Key-in Zero	Allows you to key-in known zero calibration value in case of memory loss in the field. Scrolling down with the ZERO key one level begins the procedure.	Press ZERO key to begin sequence
F20 Key-in Span	Allows you to key-in a known span calibration value in case of memory loss in the field. Scrolling down with the ZERO key one level begins the procedure.	Press ZERO key to begin sequence
F21 Factory Reset North America	This sub-menu will reset all parameters in the "F" and "A" menu to the default settings for North America. USE WITH CAUTION! "tF" message means 'busy – please wait'	Press the ZERO key twice to execute.
F22 Factory Reset Europe	This sub-menu will reset all parameters in the "F" and "A" menu to the default settings for Europe. USE WITH CAUTION! "tF" message means 'busy – please wait'	Press the ZERO key twice to execute.
F23 Analog Output Calibration	Actuates the function that allows you to calibrate the optional analog output. Pressing the ZERO key to scroll down one level begins the sequence.	Press the ZERO key to begin sequence
F24 Analog Output Function	Selects the active analog output function. "0" = 4-20 mA "1" = 0-10V	0 (NA/E) 1

CODE/NAME	DESCRIPTION	SELECTION LIST
F30 Special Application	Used to select one special application feature, subject to local legal requirements. "0" = None (Gross/Net), "1" = Accumulation, "2" = Remote Display, "3" = Piece Count, "5" = Hold, "6" = Checkweigher, "7" = Batching, " 8" Truck Weigh In/Weigh Out	0√ (NA/E) 0 - 8
F31 Gross Zero Band	Selects the range within which the scale will automatically clear the tare and switch to Gross mode. Note that the scale must be in standstill. Selections are in display divisions (d). Scrolling down with the ZERO key one level begins the procedure. "0" = Disabled	Key-in 0 - 10 0 (NA) 10 (E)
F32 Center of Zero Band	Selects the range around gross zero within which the scale will display the Center of Zero annunciator. Selections are in display divisions (d).	0.25d (US) 0.5d (E)
F34 Auto Print Min. Weight	Selects the minimum weight at which the auto print function will work if enabled. Selections are in display divisions (d). Scrolling down with the ZERO key one level begins the procedure. "0" = Disabled	Key-in 0 - 100 1 (NA/E)
F35 Hold Mode	Selects the "Hold" mode operation. See Operation section for more details. "1" = Automatic Hold, "2" = Manual, "3" = Peak Hold	1 2 3√ (NA/E)
F36 Percentage Hold Wt	Allows you to select the percentage (of the displayed held value) of weight change before the scale automatically unlocks the held weight and relocks onto the new weight. If F35 is set to "0", this function does nothing.	Key-in 0 – 100 % 10 (NA/E)
F37 Min. Hold Wt	Sets the minimum weight that can be captured and held; expressed in display divisions (d). If F35 is set to "0", this function does nothing.	1, 2, 5√ (NA/E) , 10, 20, 50, 100, 200, 500, 1000
F38 Permanent Tare	Allows a TARE to be stored with an ID number. Used for the Truck Weigh In/Weigh Out application. "0" = Disable "1" = Enable	0√ (NA/E) 1

3.5 Setup Menu Procedures

This section provides instructions for all of the Setup Menu procedures except F16 through F20. Those procedures can be found in the Calibration section.

Key-in Operation (F1, F5, F11, F31, F34 and F36)

Follow these general instructions for those parameters requiring keyed-in data:

1. While in the Setup mode, scroll to "**F xx**", and then scroll down once using the **ZERO** key. The display will momentarily show a brief description, followed the currently stored value.
2. If the displayed value is correct, simply press the ENTER or C/CE key to escape.
3. If the displayed value needs to be changed, use the front panel numeric keys to key-in the new value and then press ENTER. If you make a mistake, press the C/CE key as a backspace key. The display will show "**Set**" momentarily, and then revert back up to "**F xx**".

Calibrate analog output (F23)

Refer to applicable addendum

3.6 User Menu Descriptions

This section provides more detailed descriptions of the selections found in the User Menu Chart. Factory-set defaults are shown in bold; **(NA)** for North America and **(E)** for Europe.

CODE/NAME	DESCRIPTION	SELECTION LIST
A1 Baud Rate	Selects the baud rate for data transmission through the serial port. This menu selection has two sub-menus; "A1U1" (COM1) and "A1U2" (COM2), both with identical selections.	600, 1200, 2400, 4800, 9600√ (NA/E) , 19200, 38400
A2 Data Bits and Parity	Selects the number of data bits and parity of serial transmission. This menu selection has two sub-menus; "A2U1" (COM1) and "A2U2" (COM2), both with identical selections. "8n" = 8 data bits with no parity bit and one stop bit "7o" = 7 data bits with odd parity bit and one stop bit "7E" = 7 data bits with even parity bit and one stop bit "7n" = 7 data bits with no parity bit and two stop bits	8n√ (NA/E) 7o 7E 7n
A3 Serial Port Mode	Selects the mode of the I/O serial port: Refer to Appendix B for more information. This menu selection has two sub-menus; "A3U1" (COM1) and "A3U2" (COM2), both with identical selections. "d" = Demand Duplex "C" = Continuous Duplex "AUto" = Auto Print	d√ (NA/E) C AUto
A4 Output String	Selects fixed output string for serial port. Refer to Appendix B for details. This menu selection has two sub-menus; "A4U1" (COM1) and "A4U2" (COM2), both with identical selections. "tF" message means 'busy – please wait' "0" = Text Print Ticket Basic "1" = Text Print Ticket Accumulator "2" = Text Print Ticket Piece Counting "4" = String Format 1 (Condec Demand) "5" = String Format 2 (Condec Continuous) "6" = Truck Weigh In/Weigh Out	0√ (NA/E) 1, 2, 3, 4, 5, 6
A5 Handshaking	Selects handshaking for serial port. This menu selection has two sub-menus; "A5U1" (COM1) and "A5U2" (COM2), both with identical selections. "0" = Off (no handshaking) "1" = RTS/CTS "2" = XON/XOFF (Ctrl-Q/Ctrl-S)	0√ (NA/E) 1 2
A6 Set Time	Actuates the function that allows setting the time. Pressing the ZERO key to scroll down one level begins the programming sequence.	Press ZERO key to begin sequence
A7 Set Date	Actuates the function that allows setting of the date. Pressing the ZERO key to scroll down one level begins the programming sequence.	Press ZERO key to begin sequence

3.7 User Menu Procedures

This section provides instructions for all of the User Menu procedures.

Set Time (A6)

Your indicator will keep track of the current time for you, which can then be printed on the print ticket. Use this procedure to set the time, which must be entered in military (24-hr) format. For example, for 9:00 AM, you would enter 09.00.00. For 5:00 PM, you would enter 17.00.00.

1. While in the User Menu mode, scroll to "**A 6**", and then scroll down once using the ZERO key to enter the set time menu. The display will momentarily show "**ENT TI**", followed by the time (hh.mm.ss) currently set on the machine.
2. If the displayed value is correct, simply press the ENTER or C/CE key to exit this mode without saving any changes.
3. If the displayed value needs to be changed, first press MODE (Set). The display changes to all zeroes (00.00.00).
4. Use the front panel numeric keys to key-in the new time and then press ENTER. If you make a mistake, use the C/CE key as a backspace key. The display will show "**Set**" momentarily, and then revert back up to "**A 6**".

NEW for version 2.5 and higher: it is no longer necessary to enter the User Menu to set the time. Simply press and hold the ENTER key while powering up the unit and then follow directions are written above.

Set Date (A7)

Your indicator will keep track of the current date for you, which can then be printed on the print ticket. Use this procedure to set the date, which must be set in mm/dd/yy format. For example, for January 7, 2010, you would enter 01.07.10. For November 30, 2010 you would enter 11.30.10.

1. While in the User Menu mode, scroll to "**A 7**", and then scroll down once using the ZERO key to enter the date entry menu. The display will momentarily show "**ENT DT**", followed by the date (mm.dd.yy) current set on the machine.
2. If the displayed value is correct, simply press the ENTER or C/CE key to exit this mode without saving any changes.
3. If the displayed value needs to be changed, first press MODE (Set). The display changes to all zeroes (00.00.00).
4. Use the front panel numeric keys to key-in the new date and then press ENTER. If you make a mistake, use the C/CE key as a backspace key. The display will show "**End DT**" momentarily, and then revert back up to A7.

NEW for version 2.5 and higher: it is no longer necessary to enter the User Menu to set the date. Simply press and hold the ENTER key while powering up the unit and then follow directions are written above.

Diagnostics (A12)

Here is a brief description of each test mode:

A12U1 Display Test – Lights up all display segments, counting down from 666666 to 11111. Test ends automatically when complete.

A12U2 ADC Test – Shows internal A/D converter counts – useful for troubleshooting weighing issues. End test manually by pressing the MODE (Set) key.

A12U3 Input Test – Displays input logic (0 or 1) of input terminal (J4:3). “0” mean input pin is grounded; “1” means input pin is open. End test manually by pressing the MODE (Set) key.

A12U4 Output Test – Sets all output pins (J4:6 thru J4:9) ‘ON’. End test manually by pressing the MODE (Set) key.

A12U5 Serial Test – Transmits a data string continuously out both serial ports (“TEST1” on COM1 and “TEST2” on COM2). End test manually by pressing the MODE (Set) key.

A12U6 Keyboard Test – Displays a keycode for each key pressed on the keypad. See Table below. End test manually by pressing the MODE (Set) key.

Key	Keycode	Key	Keycode
Units	UnIts	0	0
Zero	2Ero	1	1
Tare	tArE	2	2
Print	PrInt	3	3
C/CE	CE	4	4
F1	F1	5	5
Set Point	SP	6	6
Under	UndEr	7	7
Over	ovEr	8	8
ID	Id	9	9
*	StAr	Enter	EntEr
Dec. Pt.	dP	Mode	SEt

Edit Output String (A31)

Please see Appendix B for more information.

3.8 Batch Menu Descriptions

This section provides more detailed descriptions of the selections found in the Batch Menu Chart. Factory-set defaults are shown in bold; **(NA)** for North America and **(E)** for Europe.

CODE/NAME	DESCRIPTION	SELECTION LIST
B1 Input Function	Use this menu to assign a keyboard function to the input terminal (J4:3). "0" = Print, "1" = Zero, "2" = Tare, "3" = Units, "4" = F1	0 (NA/E) 1, 2, 3, 4
B2 Input Logic	Use this menu to assign the active logic level to the input terminal (J4:3). "0" = Low logic, "1" = High logic	0 (NA/E) 1
B3 Batch Mode	Use this menu to assign the batch mode. F30 must be set to "7". "0" = Manual, "1" = Automatic, "2" = Filling, "3" = Continuous	0 (NA/E) 1, 2, 3
B4 Output Logic	Use this menu to assign the active logic level to each of the output terminals (OUT1 thru OUT4). This menu selection has four sub-menus: "B4U1" (OUT1), B4U2" (OUT2), B4U3" (OUT3), and B4U4" (OUT4), all with identical selections. "0" = Low logic, "1" = High logic	0 1(NA/E)
B5 Front Panel Access Password	There are three keys on the front panel which allow set point or over/under values to be entered into the system. Front panel access is password protected. Use this menu to assign or change the password.	Key-in 0 - 999999 336699 (NA/E)
B6 Output Trip Delay	Use this menu to assign a cutoff delay (in seconds) to each of the output terminals (OUT1 thru OUT4). This is for in-flight compensation method. This menu selection has four sub-menus; "B6U1" (OUT1), B6U2" (OUT2), B6U3" (OUT3), and B6U4" (OUT4), all with identical selections.	Key-in 0.0 – 10.0 0(NA/E)

3.9 Batch Menu Procedures

This section provides instructions for all of the Batch Menu procedures.

Key-in Operation (B5 and B6)

Follow these general instructions for those parameters requiring keyed-in data:

1. While in the Setup mode, scroll to "**B x**", and then scroll down once using the **ZERO** key. The display will momentarily show a brief description, followed the currently stored value.
2. If the displayed value is correct, simply press the ENTER or C/CE key to escape.
3. If the displayed value needs to be changed, use the front panel numeric keys to key-in the new value and then press ENTER. If you make a mistake, press the C/CE key as a backspace key. The display will show "**Set**" momentarily, and then revert back up to "**B x**".

3.10 Exiting the Menus

Exit any configuration menu by pressing the C/CE key. To exit the PASS screen, move the slide switch back to its original position. The display will go through a digit check, and then settle into Normal Operating mode.

All front panel keys will now return to their normal mode of operation.

4. CALIBRATION

4.1 Calibration Overview

If your indicator was shipped as a complete scale, then calibration is not necessary. Please check with your installer or supplier if you are unsure. Transcell recommends having your weighing equipment checked by a qualified scale technician at least once a year depending on its intended use and working environment.

The indicator requires two types of calibration: zero and span. Zero calibration (F16) requires the scale to be empty (nothing on scale) and the span calibration (F17) requires known test weights. After a successful calibration, you should record all calibration values in Table 1 using the F18 View Calibration procedure.

In the unlikely event that any calibration value is lost, the setup menu makes provisions for re-entering these values via F19 and F20; thus eliminating the need for re-calibration with test weights.

NOTE: This section assumes that the indicator is in Setup ("F") Menu mode. If the indicator is not in Setup Menu mode, refer to previous section for instructions.

4.2 Zero Calibration (F16)

1. While in the Setup mode, scroll to "**F 16**", and then scroll down once using the ZERO key to enter zero calibration menu. The display will momentarily show "**C 0**" followed by a value. This value is the internal A/D count and can prove useful when trying to troubleshoot calibration problems.
2. Remove all test weights from the platform and then press the ZERO key to zero out the displayed value.
3. Press the MODE key to save the zero point value. The display will show "**EndC0**" momentarily, and then revert back up to F16. At this time, proceed to the F17 span calibration to complete indicator calibration.

4.3 Span Calibration (F17)

1. While in the Setup mode, scroll to "**F 17**", then scroll down once using the ZERO key to enter span calibration menu. The display will momentarily show "**C 1**" for the first span calibration point, followed by a value with one flashing digit. This value will be zero with the Decimal Point parameter selected in F10.
2. Place the first test weight on the weighing mechanism.
3. Use the front panel keys to key-in the actual test weight value. There is no need to enter a decimal point, since it is fixed on the display. If you make a mistake, use the C/CE key as a backspace key.
4. After entering the exact value, press the MODE key to save the value. If the C1 calibration was successful, the display will show "**EndC1**" momentarily, followed by "**C 2**" for the second calibration point.
5. Repeat steps 2 thru 4 for C2 and C3. At the conclusion of C3, the indicator reverts back up to F17. NOTE: If you wish to use only one calibration point (C1), simply press the MODE key when prompted for C2 and C3 (do not enter in a calibration value).

- At this time it is suggested that the calibration values be recorded for future use (see next section).

If the calibration was *not* successful, one of the error messages below will appear. Take the indicated action to correct the problem, and then perform a new calibration.

"Err0" - The calibration test weight or the keyed-in weight is larger than the full capacity of the scale. Change the calibration test weight or check the input data.

"Err1" - The calibration test weight or the keyed-in weight is smaller than 1% of the full capacity of the scale. Change the calibration test weight or check the input data.

"Err2" – There is not enough input signal from the load cells to establish a proper calibration. Most common causes include incorrect load cell wiring, a mechanical obstruction or a damaged load cell.

4.4 View Calibration Values (F18)

Use this menu to view the calibration data after a successful calibration (F16 and F17). Or use the A11 menu to print this information.

- While in the Setup mode, scroll to **"F 18"**, then scroll down once using the ZERO key to enter View calibration menu. The display will show the information listed in Table 1. The code will display briefly followed by the value. It is recommended that you record each value in the table below to use as a backup.
- Press the ENTER key to continue down the list. At the completion of the list, the indicator reverts back up to F18.

CODE	NAME	VALUE
C 0	Zero Calibration Value	
T 1	First Test Weight Value	
C 1	First Span Calibration Value	
T 2	Second Test Weight Value	
C 2	Second Span Calibration Value	
T 3	Third Test Weight Value	
C 3	Third Span Calibration Value	

Table 1: Calibration Value Table

4.5 Key-in Zero Calibration Value (F19)

Note: This procedure is intended for emergency use only in the case of non-volatile memory loss. A valid zero calibration value, obtained from a successful F16 calibration procedure, must be used.

1. While in the Setup mode, scroll to "**F 19**" and then scroll down once using the ZERO key. The display will momentarily show "**CAL 0**", followed by a value of zero
2. Use the front panel keys to key-in the actual value. If you make a mistake, use the C/CE key as a backspace key.
3. After entering the exact value, press the MODE key to save the value. The display will show "**E CAL 0**" momentarily, and then revert back up to F19.

4.6 Key-in Span Calibration Value (F20)

Note: This procedure is intended for emergency use only in the case of non-volatile memory loss. Valid span calibration values, obtained from a successful F17 calibration procedure, must be used.

1. While in the Setup mode, scroll to "**F 20**", and then scroll down once using the ZERO key. The indicator will prompt you to enter the information in Table 1 or the calibration report.
2. Use the front panel keys to key-in the actual value. If you make a mistake, use the C/CE key as a backspace key.
3. After setting the exact value, press the MODE key to save the value. If the values are entered successfully, the display will show "**E**" momentarily before continuing to the next parameter.
4. Repeat Steps 2 and 3 as needed until you reach the completion of the sequence, at which point the indicator will revert back up to F20.

5. OPERATION

5.1 Display

This model utilizes a 6-digit LED (Light Emitting Diode) display along with an LED bar graph. The Table below summarizes the display annunciators.

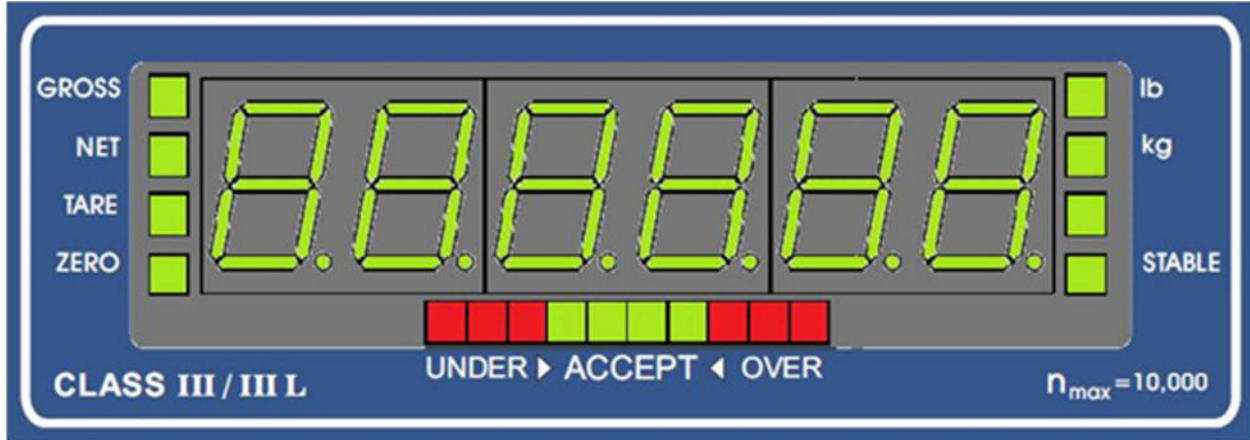

LED Annunciator	MEANING
GROSS	Indicates that the indicator is displaying gross weight.
NET	Indicates that the indicator is displaying net weight.
TARE	Indicates that a tare weight has been established in the system.
ZERO	This "Center of Zero" light is active whenever the displayed weight is within a pre-programmed band from true zero.
lb, kg	Indicates the unit of the displayed weight; lb = pounds, kg = kilograms.
STABLE	This light is on whenever the scale is no longer in motion.
UNDER	Checkweigher mode only – indicates that the weight on the platform is below the target weight
ACCEPT	Checkweigher mode only – indicates that the weight on the platform is within the range of the target weight
OVER	Checkweigher mode only – indicates that the weight on the platform is above the target weight

TI-1680 Annunciator Definitions

NOTE: When not in checkweigher mode, the LED bar graph shows the status (ON/OFF) of each of the four outputs:



5.2 KEYBOARD

The keyboard is composed of a total of twenty-four (24) keys. There are twelve (12) function keys and twelve (12) numeric keypad keys.



FUNCTION KEYS

UNITS – This key toggles the indicator among lb, kg and third unit if enabled in the Setup (“F”) menu.

ZERO - This key sets the indicator to display zero as long as the following conditions are met:

1. The indicator is displaying Gross weight.
2. The displayed weight is within the zero reset range that is programmed in F4 of the Setup (“F”) Menu.
3. The scale is not in motion.
4. The scale is not in overload (see Appendix D for error codes).

MODE – If a system Tare has been established, this key toggles the display among Gross weight, Net weight and Tare weight. Additional information may be displayed depending upon the application (see F30).

TARE - This key is used to establish a Tare weight as long as the following conditions are met:

1. The indicator is not at or below Gross zero.
2. The scale is not in motion.
3. The scale is not in overload (see Appendix D for error codes).

PRINT - This key is used to manually send weight information out to both serial ports as long as the following conditions are met:

1. The scale is not in motion.
2. The scale is not in overload (see Appendix D for error codes).

C/CE – This key is used to exit a current function or to backspace thru a numeric entry.

F1 – This key is used as the main function key for a specification application, e.g. piece counting or peak hold. See the F30 sub-menu for more information.

SET POINT – This key is used to enter in up to four set points thru the front panel. This key is password protected. See Programming Set Points for more information.

UNDER – If the indicator is configured for the over/under checkweigher application (see F30 and B7), this key is used to enter in the ‘under value’ thru the front panel. This key is password protected. See Programming Over/Under Values for more information.

OVER – If the indicator is configured for the over/under checkweigher application (see F30 and B7), this key is used to enter in the ‘over value’ thru the front panel. This key is password protected. See Programming Over/Under Values for more information.

ID – This key is used to enter in a system ID number which can be sent out to any serial port (COM1 or COM2). See Entering an ID Number for more information.

ENTER – Main key used to enter information or selections into the indicator.

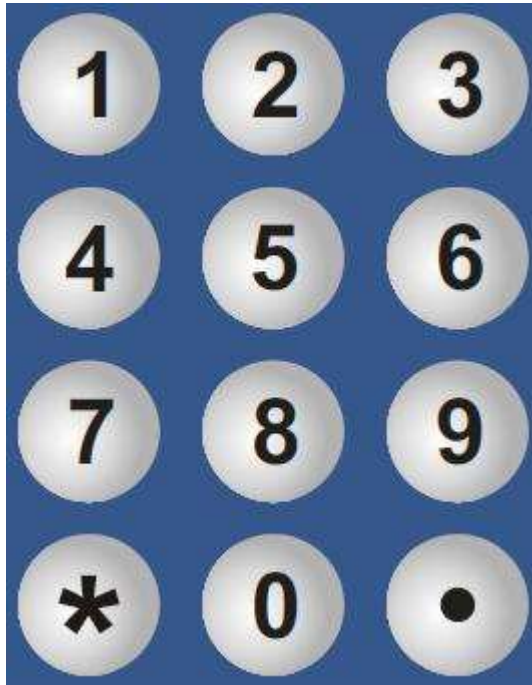

NUMERIC KEYS

0 - 9 – These keys allow numeric entry where applicable, e.g. keyboard tare entry.

***** – Used to temporarily display information based upon current application (F30).

• – This key inserts a decimal point to a numeric keyboard entry.

5.3 GENERAL SCALE OPERATION

WEIGHING AN ITEM

1. Select the desired weighing unit (lb or kg) by pressing the UNITS key until that unit is indicated on the display.
2. If necessary, press the ZERO key to obtain a weight reading of zero.
3. If weighing an item in a container, place the empty container on the scale's platter and, after allowing the weight indication to stabilize, press the TARE key. The display switches to NET weight mode.
4. Place the object to be weighed on the scale's platter and allow the weight indication to stabilize. If the item weight exceeds the scale's weight capacity, it displays "ooooo".
5. Read the weight shown on the display. If you have established a tare, you may toggle among the gross, net and tare weights by pressing the MODE key.

ENTERING A KNOWN TARE WEIGHT

1. Select the weighing unit (lb or kg) of the known tare weight by pressing the UNITS key until that unit is indicated on the display.
2. Using the front panel numeric keys (0-9), enter the known tare weight. (decimal point position is fixed)
3. Press the TARE key. The display switches to NET weighing mode.
NOTE: If the entered tare weight is out of range, for example if it exceeds scale capacity, the tare weight will be rejected.
4. Place the object to be weighed on the scale's platter and allow the weight indication to stabilize. If the item weight exceeds the scale's weight capacity, it displays "oooooo".
5. Read the weight shown on the display. You may toggle among the gross, net and tare weights by pressing the MODE key

CLEARING A TARE WEIGHT

- Use the MODE key to return to GROSS weight mode and then press the ZERO key.

ENTERING AN ID NUMBER

NOTE: To utilize this feature properly, the 'Print Out ID Number' Print Command (PRID) should be programmed into your output string. See Appendix B for more information.

The indicator stores one ID number. The default value is 123456. The number is retained in memory even after the unit is powered off.

1. Press the ID key. The display will display the currently stored ID number value.
2. If the displayed value is correct, simply press the ENTER or C/CE key to escape.
3. If the displayed value needs to be changed, use the front panel numeric keys to key-in the new value and then press ENTER. If you make a mistake, press the C/CE key as a backspace key.

PROGRAMMING SET POINTS

For certain applications, the indicator supports four (4) weight set points, each one corresponding to an output. For example, set point value #1 corresponds to OUTPUT1; set point value #2 corresponds to OUTPUT2, etc. The values are retained in memory even after the unit is powered off.

1. Press the Set Point key. The display shows "PASS_" to indicate that you need to enter a password to access this programming mode.
2. Key-in the front panel access password (programmed thru B5) and then press the Enter key. The display will show "SP1" briefly and then the currently stored set point #1 value.
3. If the displayed value is correct, simply press the ENTER to move to the next set point. Or you can press the C/CE key to exit
4. If the displayed value needs to be changed, use the front panel numeric keys to key-in the new value and then press ENTER. If you make a mistake, press the C/CE key as a backspace key. The display will show "SET" briefly, followed by "SP2" and finally the currently stored set point #2 value.

5. Repeat Step 3 and 4 until all four values are programmed. If you do not wish to utilize a set point, then please set its value to zero. The indicator returns to normal operating mode at the completion of the programming sequence.

PROGRAMMING OVER/UNDER VALUES

For certain applications, (see next section) the indicator supports one 'over' value and one 'under' value. The values are retained in memory even after the unit is powered off.

1. Press the Under key. The display shows "PASS_" to indicate that you need to enter a password to access this programming mode.
2. Key-in the front panel access password (programmed thru B5) and then press the Enter key. The display will show the currently stored 'under' value.
3. If the displayed value is correct, simply press the ENTER or C/CE key to escape.
4. If the displayed value needs to be changed, use the front panel numeric keys to key-in the new value and then press ENTER. If you make a mistake, press the C/CE key as a backspace key. The display will display "SET" briefly and then return to normal operating mode.
5. Press the Over key. The display shows "PASS_" to indicate that you need to enter a password to access this programming mode.
6. Repeat Step 2 thru 4 for the 'over' value.

6. ADVANCED SCALE OPERATION

6.1 APPLICATION (F30) SUMMARY

The following table summarizes the various parameters and operation for each application programmed in the F30 setup menu:

F30	Set Point key	Over/Under Keys	Output Function	* key operation	F1 key operation
Gross/Net/Tare (0)	Active (4)	Not active	Standard Outputs	No function	No function
Accumulator (1)	Not active	Active (1) (total weight)	Checkweigher Outputs	Trans counter, Gross Total, Net Total	Print Total & Clear
Remote Display (2)	Not active	Not active	Not active	Not active	Not active
Piece Counting (3)	Not active	Active (1) (Pieces)	Checkweigher Outputs	APW	Sample
Hold (5)	Not active	Active (1) (Weight)	Checkweigher Outputs	No function	Activate Hold
Checkweigher (6)	Not active	Active (1) (Weight)	Checkweigher Outputs	No function	Target Weight
Batching (7)	Active (4)	Not active	See Batching section	No function	Start/Stop Batch
Weigh in/out (8)	Not active	Clear ID's	Not active	Not active	Enter Truck ID #

6.2 STANDARD OUTPUTS

Each output tracks its corresponding set point. For example, Output 1 tracks Set Point 1; Output 2 tracks Set Point 2, etc. Note that the outputs continuously track the weight, i.e. they will re-fire when the weight drops back below a set point.

For in-flight compensation, use the Cutoff delay (B6)

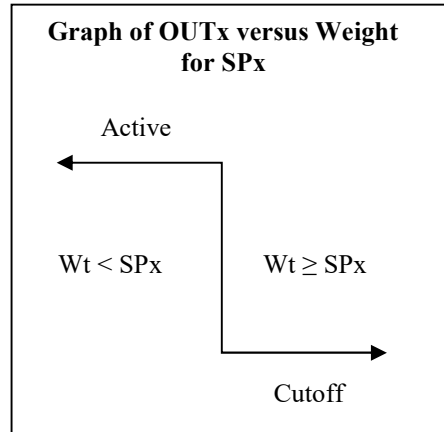

6.3 ACCUMULATION APPLICATION (F30 = 1)

The Print key is used to add a weight to the accumulator and increment the transaction counter. The system weight must return to zero before another weight can be added.

The F1 key is used to print out the total and then reset the accumulator to zero.

Press the * key to briefly display the following information:

Transaction Counter => Gross Weight Total => Net Weight Total

Use the Over and Under keys to program in a Total Weight target for checkweigher.

6.4 REMOTE DISPLAY APPLICATION (F30 = 2)

Only the UNITS, ZERO, MODE AND TARE keys operate in this mode. No other keys will function.

All four outputs stay in CUTOFF state and the input is not recognized.

6.5 PIECE COUNT APPLICATION (F30 = 3)

IMPORTANT NOTE: The piece counting application cannot be used in commercial (NTEP) applications.

This application is used to indicate the number of pieces of an item you have placed on the scale's platform. To ensure accuracy, the parts you are counting must be consistent in weight.

Upon power up, this mode works a lot like the Gross/Net/Tare mode. Use the F1 key to activate the piece counting mode. Once in piece counting mode, the UNITS key becomes inactive.

Press the * key to briefly display the following information:

APW (Average Piece Weight)

To exit the piece counting mode and return to weighing mode, press the C/CE key.

The indicator uses the sampling method to determine the average piece weight (APW) of the items you wish to count. When sampling items, always count the parts in your hand and place them on the platform all at once. If the APW of the items is too light or the total weight of the sample is too light, accuracy cannot be guaranteed. You will get an error message, but piece counting will still be allowed. This indicator does not retain the piece weight when powered down.

1. If the items you will be counting require a container, you must first tare the container off by pressing the TARE key.
NOTE: The TARE key is inoperative when in sampling mode.
2. Press the F1 key. The screen shows "10" which is the default sample size.
3. Use the numeric keys to key-in the actual size of the sample (if different), e.g. 20, 50, 100, etc.
4. Place the sample items on the platform all at once and allow the weight indication to stabilize.
5. Press the ENTER key to take the sample. If the sample size is large enough, the indicator now displays the number of pieces on the platform and the unmarked annunciator is lit. If not, the indicator briefly displays "Lo" and returns back to weighing mode.

NOTE: If you encounter the "Lo" message, try increasing the sample size. If you continue to see the "Lo" message, then the unit weight of the items you wish to count is too light for your scale to process accurately.

6. To exit the piece count mode, press the C/CE key.
NOTE: The APW will NOT remain in scale memory when you exit piece counting mode.

If you already know the APW of the items you wish you count, may simply key-in the value instead of taking a sampling. **Please ensure that the indicator is displaying the correct unit of measure (lb or kg) before starting.**

1. Press the Enter key; the display flashes "APW" three times and then shows a zero value with a fixed decimal point position.
2. Using the numeric keys, key-in the APW value and then press Enter. The indicator automatically switches to PCS mode.
NOTE: If you encounter the "Lo" message, then the unit weight of the items you wish to count is too light for your scale to process accurately.

Use the Over and Under keys to program in a pieces target for checkweigher.

6.6 HOLD APPLICATION (F30 = 5)

There are several specific hold modes, which are selected thru the F35 setting:

AUTOMATIC (F35 = 1) – Automatically locks weight on the display when stable. The percentage hold setting (F36) unlocks the held reading and relocks onto the new weight. This occurs during both increasing and decreasing weight values.

MANUAL (F35 = 2) – Press the F1 key before applying any weight to the scale. After the load has stabilized, the display will hold the weight reading on the screen until the F1 key is pressed again. The percentage hold setting (F36) unlocks the held reading and relocks on the new weight for increasing weights only.

PEAK HOLD (F35 = 3) – The display updates as the load increases but not as the load decreases. The value shown on the screen is the maximum weight applied to the scale. Press the F1 key to activate peak hold mode. Press F1 again to exit peak hold mode and clear the peak value.

Use the Over and Under keys to program in a target weight for checkweigher.

6.7 CHECKWEIGHER APPLICATION (F30 = 6)

This mode is used to visually show a user if the materials on the scale meet, exceed or fall short of the target weight. These conditions correspond to ACCEPT, OVER and UNDER respectively.

There are two specific checkweigher modes, which are selected thru the A18 setting:

COARSE (A18 = 0) – Once the values are programmed, all LED bars stay lit according to the current condition.

FINE (A18 = 1) – Once the values are programmed, each vertical bar on the LED represents one scale graduation, e.g. if two LED bars are lit in the UNDER range, then you are two scale graduations away from achieving ACCEPT.

All vales are set thru use of the front panel. There are two ways to program the target weight values. A password is required for each method:

OVER/UNDER – The upper and lower limits for the ACCEPT range are programmed into the scale thru the corresponding keys on the front panel.

TARGET – The target weight is derived from the weight applied to the scale platform. Place the target weight onto the scale platform and then press the F1 key to store it.

The outputs take on special meanings for this application.

OUT1 – This output automatically tracks the OVER range. When operating within the OVER range, the output is in ACTIVE state. When operating outside of the OVER range, the output is in CUTOFF state.

OUT2 – This output automatically tracks the UNDER range. When operating within the UNDER range, the output is in ACTIVE state. When operating outside of the UNDER range, the output is in CUTOFF state.

OUT3 – This output automatically tracks the ACCEPT range. When operating within the ACCEPT range, the output is in ACTIVE state. When operating outside of the ACCEPT range, the output is in CUTOFF state.

OUT4 – Remains permanently in CUTOFF state.

6.8 BATCHING APPLICATION (F30 = 7)

The batching application is designed for gain-in weight material batching. The TI-1680 will allow batching of up to four materials using in-flight compensation or up to two material using fast/slow valves. The TI-1680 does not have a provision for dumping the batch when complete, so this must be done manually.

The outputs fire sequentially like this:

Weight	OUT 1	OUT 2	OUT 3	OUT 4
$wt \leq SPT1$	ON	OFF	OFF	OFF
$SPT1 < wt \leq SPT2$	OFF	ON	OFF	OFF
$SPT2 < wt \leq SPT3$	OFF	OFF	ON	OFF
$SPT3 < wt \leq SPT4$	OFF	OFF	OFF	ON
$SPT4 < wt$	OFF	OFF	OFF	OFF

The outputs will not re-fire when the batch is dumped. For in-flight compensation, use the Cutoff delay (B6)

The TI-1680 will automatically tare the scale upon batching start, but it will not auto tare between each set point. Therefore, you must use total weights when programming set points.

There are three batching modes, which are selected thru the B3 setting:

MANUAL (B35 = 0) – The F1 key must be used to step the scale thru each set point.

AUTOMATIC (B35 = 1) – The F1 key must be pressed to start the batching process but once started, the indicator runs thru each set point automatically. Once complete, the F1 key must be pressed again to start the new batch.

FILLING (B35 = 2) – This mode is like automatic mode in that you press the F1 key once to start the process. The difference lies in the output logic. The outputs will operate like the Standard Outputs. However, the outputs will not re-fire when the filling operation is complete.

CONTINUOUS (B35 = 3) – This mode is like automatic mode in that you press the F1 key once to start the process. The difference is that you need not press the F1 key to begin each batch.

6.9 TRUCK WEIGH IN/WEIGH OUT APPLICATION (F30 = 8)

The truck weigh in/weigh out application is designed for weighing material being loaded or unloaded on a vehicle. The TI-1680 will allow for up to 256 individual vehicles to be weighed in & out.

All instructions can be found below. After a successful operation, the indicator will automatically revert back to normal operating mode.

Use the C/CE key at any time to exit a function. If no key entry is made within a few seconds, the indicator automatically reverts back to normal operating mode.

Truck In

1. With the truck on the scale, press the F1 key. "Ent Id" will be displayed.
2. Press the Enter key to automatically assign an ID number and then press Enter. Alternately, you can use the 0-9 keys to key-in in the vehicle ID number (up to 999999) and then press Enter. The indicator will display "In".
3. If a printer is connected, a ticket will automatically be printed.

Truck Out

1. With the truck on the scale, press the F1 key. "Ent Id" will be displayed.
2. Use the 0-9 keys to key-in in the vehicle ID number (up to 999999) and then press Enter. The indicator will display "Out".
3. If a printer is connected, a ticket will automatically be printed.

Print all ID numbers

1. Press the ID key. The indicator will display "Prt Id".
2. Press the Enter key to print all stored ID numbers.

More =>

Clear one ID number

1. Press the Under key. The indicator will display “CLr Id”.
2. Press the Enter key to begin.
3. Use the 0-9 keys to key-in the ID number you wish to delete and then press the Enter key. The ID number will be deleted.

Clear all ID numbers

1. Press the Over key. The indicator will display “CLrALL”.
2. Press the Enter key. All ID numbers will be deleted.

Duplicate print-out

1. Press the Print key. The last ticket will be re-printed.

Truck In – Store keyboard tare weight

NOTE: First make sure F38 (permanent tare) is set to ‘1’

1. With the truck on the scale, press the F1 key. “Ent Id” will be displayed.
2. Use the 0-9 keys to key-in an ID number and then press the Tare key. The indicator will display “In” and “TArE”.
3. Press the Enter key. The indicator will display “Ent tr”.
4. Use the 0-9 keys to key-in the tare weight and then press Enter. The tare weight is now saved.
5. If a printer is connected, a ticket will automatically be printed.

Truck In - Store current weight as the tare weight

NOTE: First make sure F38 (permanent tare) is set to ‘1’

1. With the truck on the scale. Press the F1 key. “Ent Id” will be displayed.
2. Use the 0-9 keys to key-in an ID number and then press the Tare key. The indicator will display “In” and “TArE”.
3. Press the Tare key. The indicator will display the current weight.
4. Press [Enter]. The indicator will display “SEt”. The tare weight is now saved.
5. If a printer is connected, a ticket will be printed.

Truck Out - Using Stored Tare Weight

NOTE: First make sure F38 (permanent tare) is set to ‘1’

1. With the truck on the scale, press the F1 key. “Ent Id” will be displayed.
2. Use the 0-9 keys to key-in an ID number and then press the Enter key. The indicator will display “Out”.
3. If a printer is connected, a ticket will be printed.

7. LEGAL FOR TRADE SEALING

Indicators can be sealed for commercial (Legal for Trade) applications as follows.

1. On the back of the indicator, locate the setup/calibration switch cover.
2. Thread a wire security seal through both drilled head screws securing the calibration switch cover as well as the single drilled head screw holding on the rear panel.

APPENDIX A: SPECIFICATIONS

ANALOG SPECIFICATIONS

Full Scale Input Signal	±3.125 mV/V
Minimum Sensitivity - Non trade	0.3 μ V / grad
Minimum Sensitivity - H-44	0.6 μ V / grad
Input Impedance	30M Ω , typical
Internal Resolution	Approximately 130,00 counts @ 1mV/V input
Display Resolution	50,000 display division max
Measurement Rate	10 Hz/80 Hz selectable
System Linearity	Within 0.02% of FS
Calibration Method	Software Calibration, with long term storage in EEPROM
Excitation Voltage	+5 VDC, 12 x 350 Ω load cells

DIGITAL SPECIFICATIONS

Microcontrollers	Silabs C8051F340
Program Memory	64K x 8, internal to μ C
SRAM:	2Kx 8, internal to μ C
EEPROM:	256 x 8, external to μ C, 8K x 8, external to μ
Digital Filtering	Software selectable

SERIAL COMMUNICATIONS

Serial Ports (Both)	Full Duplex, selectable Baud rate 8 data bits, no parity, 1 stop bit 7 data bits, odd parity, 1 stop bit 7 data bits, even parity, 1 stop bit 7 data bits, no parity, 2 stop bits
---------------------	---

CONTROL I/O

Outputs	Four cutoff outputs, open collector design
Input	One configurable logic level input for keyboard functions

OPERATOR INTERFACE

Display	1" (25 mm) 7-segment, LED, 6 Digit
Additional Symbols	Net, Gross, Stable, Tare, lb, kg, Zero, Over, Under, Accept
Keyboard	24-key flat membrane switch

POWER

Mains	100-240 VAC, 50/60 Hz, 30W
DC Power Consumption	200mA + 15mA/350 Ω Load Cell
Fuse (Internal)	1A 250V SLOW BLOW

ENVIRONMENTAL

Operating Temperature	-10° to +40° C (14° to 104° F)
Storage Temperature	-25° to +70° C (-13° to 158° F)

MECHANICAL

Overall Dimensions (L x W x H)	12.2" x 8.15" x 3.94" (310mm x 207mm x 100mm)
--------------------------------	---

APPROVALS

NTEP	CC # 10-078
Canada	NOA # AM-5801

APPENDIX B: SERIAL PORT INFORMATION

SERIAL PORT MODES

DEMAND DUPLEX MODE

The Demand Duplex Mode provides a two way serial transmission mode. In this mode, the output information is transmitted on demand; either by pressing the PRINT key on the indicator's front panel or upon receiving a recognized command from a host device (i.e. computer).

NOTE: Ensure that your cabling contains the proper handshaking.

CONTINUOUS DUPLEX MODE

The Continuous Duplex Mode provides a two-way serial transmission mode. In this mode, the output information is transmitted continuously making it a popular choice for remote displays and other remote devices requiring a constant data stream. The transmission automatically occurs at the end of each display update. The indicator will react upon receiving a recognized command from a host device.

RECOGNIZED HOST COMMANDS (applies to demand duplex mode only)

- "P"** - This command is sent to the indicator to print the indicated display. The indicator will not respond if the scale is in motion, positive overload or negative overload.
- "Z"** - This command is sent to the indicator to zero the scale. The indicator will not respond if the scale is in motion, positive overload or negative overload. The indicator will also not respond if it is in net mode or outside the zero range specified in F4 of the Setup Menu.
- "T"** - This command is sent to the indicator to tare the scale. The indicator will not respond if the scale is in motion, positive overload or negative overload. The indicator will also not respond if it displaying a negative gross value.
- "G"** - This command is sent to the indicator to switch to gross mode. The indicator will not respond if the scale is in motion, positive overload or negative overload.
- "N"** - This command is sent to the indicator to switch to net mode. The indicator will not respond if the scale is in motion, positive overload or negative overload. The indicator will also not respond if a tare has yet to be established.
- "C"** - This command is sent to the indicator to toggle among the configured units of measure.

AUTO PRINT MODE

The Auto Print Mode provides a one-time serial transmission once a non-zero, stable condition is achieved

OUTPUT STRING

The indicator contains one editable output string (print format). You can simply choose one of three output strings already created for you or you can edit one of the pre-defined output strings to suit your application.

Output strings are created by assigning a hexadecimal value to a decimal address. The addresses start at 0 (displayed as 00) and end at 94. The HEX value can be a printable ASCII character or a print command. Below please find a table of print commands.

Print Commands

Dec	Hex	Printing Action	(abbrev.)	Parameter
128	80	Gross weight	(GWT)	
129	81	Net weight	(NWT)	
130	82	Tare weight	(TWT)	
131	83	Print the data on screen	(CWT)	
132	85	Units (lb, kg, PCS, etc)	(UN)	
133	86	Date	(DAT)	
134	87	Time	(TIM)	
135	88	'O' = Over/Under; 'M'=Motion	(STAT)	
136	89	Gross/Net flag: 'G/N'	(GN)	
137	8A	MP20 printer to print header info.	(MP20)	
149	8C	Print out ID number.	(PRID)	
140	8D	No. of line feeds.	(PRLF)	1-99 (Dec)
141	8E	No. of spaces.	(PRSPS)	1-99 (Dec)
142	90	Unit flag: 'L/K'	(LK)	
143	91	Unit flag: 'LB/KG'	(LBKG)	
144	92	Gross/Net flag: 'GR/NT'	(GRNT)	
145	93	Gross Total Weight	(GTOT)	
146	94	Net Total Weight	(NTOT)	
147	95	Transaction Number	(TRANS)	
148	96	Pieces	(PRPCS)	
149	97	Percentage	(PRPCT)	
0	00	Null	(NUL)	
255	FF	End of String	(EOS)	

NOTES:

1. The decimal values are provided only for reference; use HEX values when programming.
2. All output strings should end with an EOS character.
3. The Null character can be used to comment out a line when editing pre-defined output strings. In this manner an unnecessary line can simply be skipped, i.e. not printed.

TEXT PRINT TICKET

The Text Print Ticket is designed specifically for a serial printer.

ID.NO. 123456
 DATE 01/28/09
 TIME 10:23 AM
 GROSS 1067 lb
 TARE 67 lb
 NET 1000 lb

Address (Dec)	Value (Hex)	Chart	Address (Dec)	Value (Hex)	Charts
00	49	I	29	4F	O
01	44	D	30	53	S
02	2E	.	31	53	S
03	4E	N	32	80	(GWT)
04	4F	O	33	85	(UN)
05	2E	.	34	0D	CR
06	8C	(PRID)	35	0A	LF
07	0D	CR	36	54	T
08	0A	LF	37	41	A
09	44	D	38	52	R
10	41	A	39	45	E
11	54	T	40	20	‘ ’
12	45	E	41	82	(TWT)
13	8E	(PRSPS)	42	85	(UN)
14	04	4	43	0D	CR
15	86	(DAT)	44	0A	LF
16	0D	CR	45	4E	N
17	0A	LF	46	45	E
18	54	T	47	54	T
19	49	I	48	20	‘ ’
20	4D	M	49	20	‘ ’
21	45	E	50	81	(NWT)
22	8E	(PRSPS)	51	85	(UN)
23	04	4	52	0D	CR
24	87	(TIM)	53	0A	LF
25	0D	CR	54	8D	(PRLF)
26	0A	LF	55	08	8
27	47	G	56	FF	EOS
28	52	R			

Edit Output String (A14)

The programming format is AA__vv where AA is the address (00 to 94) and vv is the programming value (remember a value can be either a printable ASCII character or a print command.)

1. While in the User Menu mode, scroll to "**A 14**", and then scroll down once using the ZERO key to the A14 U1 level.
2. Use the Use the right arrow key (PRINT) to select the A 14 U1 or A14 U2 menu.
3. At the A14 Ux screen, scroll down once using the ZERO key to enter the edit output string menu. The display will show the programming format, e.g. 00 49 where 00 is address 0 and 49 is the current programming value in hex.
4. Use the right arrow key (PRINT) to increase the address by one. Use the left arrow key (TARE) to decrease the address by one.
5. After selecting the address you want to change, press the MODE key. The programming value will start flashing. Increase the flashing digit by pressing the UNITS key. Decrease the flashing digit by pressing the ZERO key. Pressing the PRINT key or the TARE key will change the position of the flashing digit.
6. After setting the exact programming value, press the MODE key to save. The indicator will automatically increment to the next address.
7. Repeat Steps 3 and 4 until the entire output string has been programmed.
8. Press the UNITS key to exit A14 menu mode.

APPENDIX C: DISPLAYED ERROR CODES

CODE	MODE	MEANING / POSSIBLE SOLUTION
□□□□□□	Normal Operating Mode	Gross Overload. A weight greater than the rated capacity has been applied to the scale. Remove the weight from the platter or try re-calibrating the scale. Otherwise, check for a bad load cell connection or possible load cell damage due to overloading.
Err 0	Span Calibration Mode (F17)	Keyed-in weight value is larger than full-scale capacity. Use a smaller test weight or check keyed-in value.
Err 1	Span Calibration Mode (F17)	Keyed-in weight value is less than 1% of full-scale capacity. Use a larger test weight or check keyed-in value.
Err 2	Span Calibration Mode (F17)	There is not enough load cell signal to produce the internal counts necessary to properly calibrate the scale. First check all load connections. Use F16 mode to view internal counts.
Err 3	All Modes	Non-volatile memory read error. One or more setup parameters have been lost.
Err 4	All Modes	Non-volatile memory write error. Indicator needs service.
Err 5	Key-in Span Calibration Mode (F20)	You have attempted to enter a zero value for C1. Enter a known calibration value greater than zero.
Err 6	Normal Operating Mode	Keyboard tare value exceeds scales capacity. Please choose a tare value equal to or less than scale capacity.
Err 9	Normal Operating Mode	Span calibration value has been lost. Re-calibrate the scale.
Err 10	Normal Operating Mode	Not in Gross mode (weigh in/weigh out mode only)
Err 11	Normal Operating Mode	Negative weight not permitted (weigh in/weigh out mode only)

APPENDIX D: WIRING EXTERNAL OUTPUT RELAYS

OUTPUTS

The outputs can be wired thru an external relay(s) (not included) to switch on/off inductive loads. There are two ways to drive the external relay(s):

1. Using internal power supply from TI-1680
2. Using an external power supply (not included)

If you are using the internal power supply, then your relay must be able to operate with 5VDC.

Internal Power Supply

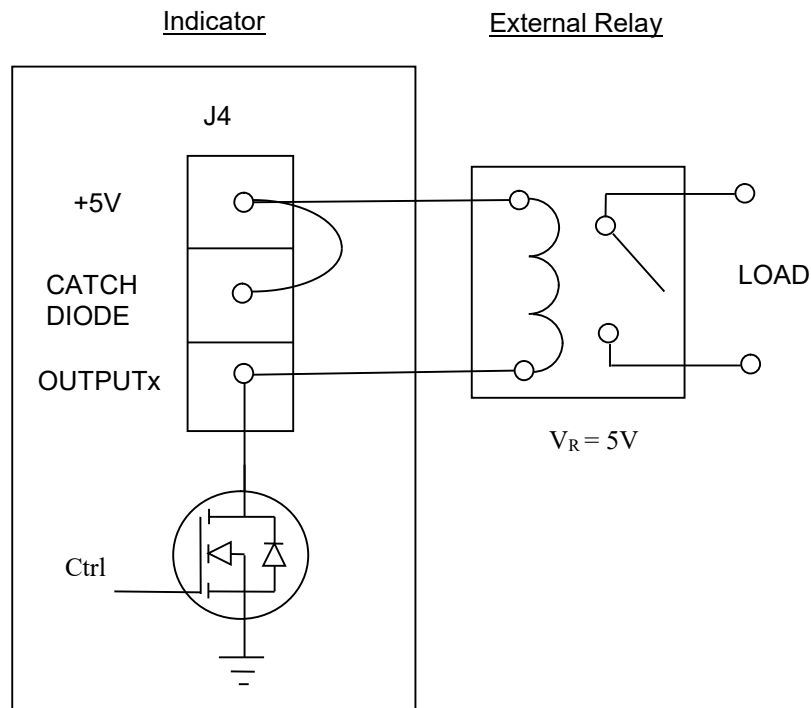

NOTE: The CATCHDIODE connection is not required when using a solid state relay(s).

External Power Supply

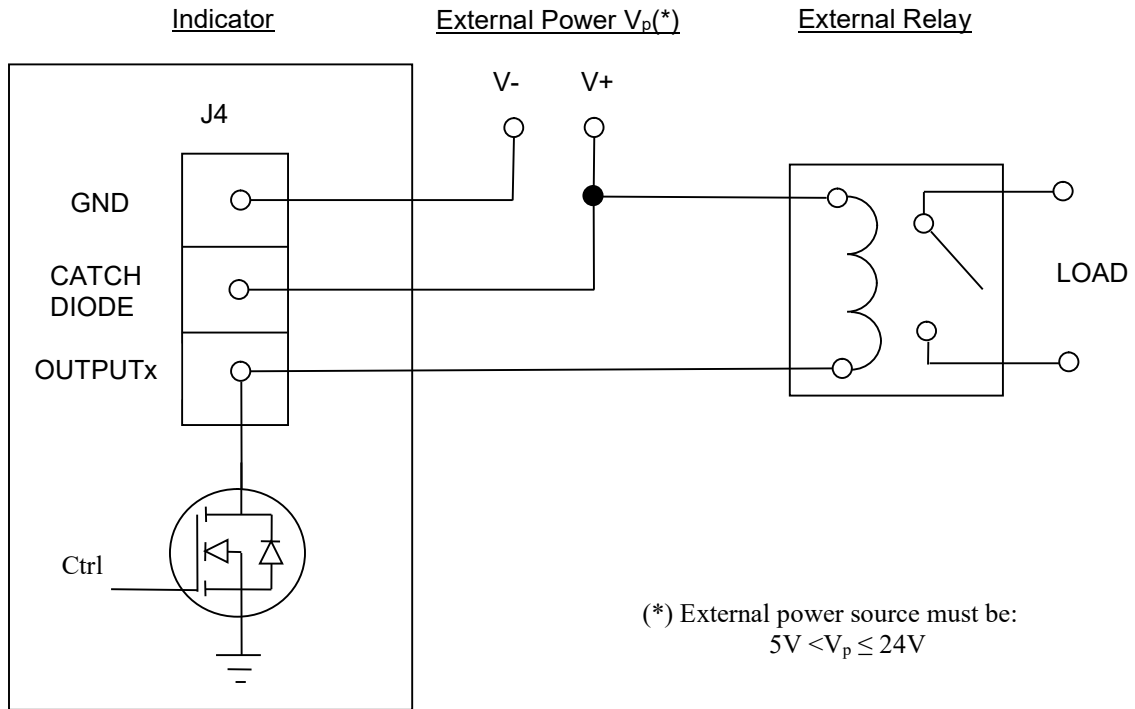

NOTE: The CATCHDIODE connection is not required when using a solid state relay(s).

INPUTS

You can wire a remote switch (not included) to act as the batch start/stop switch. This can be used in addition to - or instead of - the front panel UNITS key. A momentary, normally open switch is recommended.

